

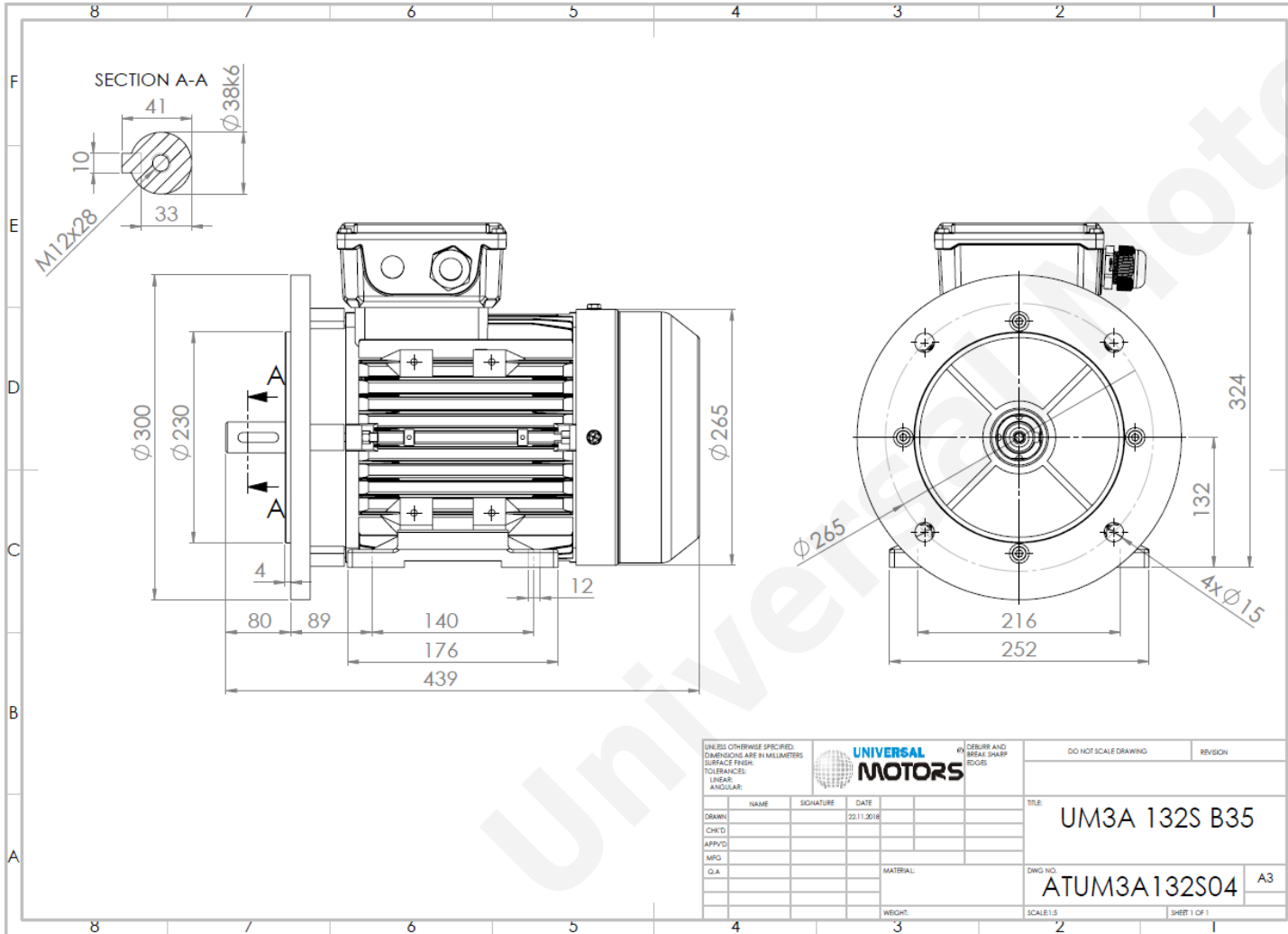

TECHNICAL DATA

Three Phase Electric Motors - Aluminum Frame
 PE31 132S-8
 2.2 kW / 3 Cv
 720 RPM



Motor type:	PE31 132S-8
Output:	2.2 kW / 3 Cv
Speed (min ⁻¹):	720 RPM
Frequency:	50 Hz
Voltage:	400 V
Current:	5.4 A
Power factor (Cos Ø):	0.705
Poles:	8
Insulation class:	F
Temperature rise Class:	B
Efficiency 50%:	80.8 %
Efficiency 75%:	82.7 %
Efficiency 100%:	81.6 %
Torque:	29.2 N.m
Tstarting/Tnominal:	2.1
Istarting/Inominal:	5.0
Tmaximum/Tnominal:	2.6
Noise:	70 Db(A)
Weight:	42.5 Kg
Bearing DE:	6308 2Z C3
Bearing NDE:	6308 2Z C3

Regime - S1

Altitude - 1000m

Environment Temperature - 40°C

CONTACTS:

UNIVERSAL MOTORS Tel: +351 252 299 080
 Rua de São Brás,745 Fax: +351 252 299 089
 4480-782 VILA DO CONDE Mail: geral@universalmotors.pt

* References applied only in the UK